

# General Specifications

GS 05D01D13-01E

Model UT351-xA  
Digital Indicating Controller  
with Active Color PV Display  
and Embedded Ethernet



## General

Model UT351 Digital Indicating Controller is a highly accurate 1/4 DIN controller provided with the Ethernet communication functions. It has a large display for readings with the PV display color changing function "Active Color PV Display", universal input/output and excellent monitoring operability with Auto/Man switching key. In addition, auto-tuning, the overshoot suppressing function "SUPER", the hunting suppressing function "SUPER2" and heating/cooling control are available as control functions, and a retransmission output is also equipped as standard. As described above, the UT351 is a controller provided with higher functions and capability.

\* "Ethernet" is registered trademark of XEROX Corporation.

## Main Features

- Embedded Ethernet communication function is available. Connectivity to host devices is provided by MODBUS/TCP protocol.
- The UT351 can use the Ethernet serial gateway function to relay a host device with Ethernet communication function and a device with the RS485 serial communication function (MODBUS/RTU protocol) such as an GREEN Series controller, UT100 Series controller, POWERCERT Series and JUXTA Series.
- Extra-large digital display allows the indicated values to be read even from a long distance. LEDs of 20mm height are used for the PV display.
- The PV display color changing function "Active Color PV Display" is provided. PV display color is changed from green to red and vice versa when an alarm occurs or deviation becomes large. The color also can be fixed in green or red.
- Universal input and output enable users to set or change freely the input type PV (thermocouple, RTD, or mV), PV input range, and type of control output (4 to 20mA current, voltage pulse, or relay contact), etc. from the front panel.
- Parameters can easily be set using a personal computer. ("Parameter setting tool (model LL100)" sold separately is required.)

## Function Specifications

### Control Computation Functions

Control computation:

Can be selected from the following types:  
Continuous PID control, Time-proportional PID control, Heating/Cooling control (for heating/cooling type only) or Relay ON/OFF control.

Control cycle time: 250 ms

Number of sets of target setpoints and PID parameters: 4

Target setpoint and PID parameter selection:

PID parameters are provided for every target setpoint and the set of PID parameters are selected at the same time that the setpoint number is selected.

### UT351



Indication in green or red color

### UT351E

"E" indicates the model with expanded functions.

### Zone PID selection:

PID parameters are selected depending on the value of the PV. For selection, the reference point (PID parameter selection setpoint) or the reference deviation is used.

### Reference point method:

The PV input range is divided into a maximum of three zones with up to two reference points, and PID parameters are selected (No. 1 PID to No. 3 PID) for every zone.

Reference point = PV input range (0%) ≤ Reference point 1 ≤ Reference point 2 ≤ PV input range (100%)

Reference point hysteresis = Fixed to 0.5% of the PV input range span.

### Reference deviation method:

PID parameters (No. 4 PID) are selected when the deviation exceeds the reference deviation. This process takes precedence over the reference point method.

Reference deviation = OFF or 0.1 to 100.0% of PV input range span.

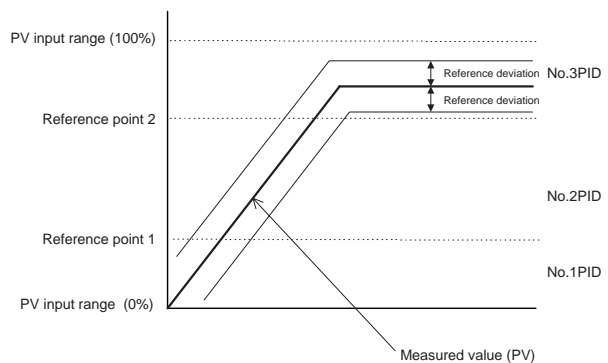

**Auto-tuning:**

Available as standard. If auto-tuning is operated, PID parameters are automatically set (limit cycle method).

**“SUPER” function:**

Overshoots generated by abrupt changes in the target setpoint or by disturbances can be suppressed.

**“SUPER2” function:**

The function stabilizes the state of control that is unstable due to hunting, etc. without requiring any change in PID constants, when the load and/or gain varies greatly, or when there is a difference between the characteristics of temperature zones.

**Control Parameters Setting Range**

Proportional band = 0.1 to 999.9%

0.0 to 999.9% for heating/cooling control,  
0.0% for ON/OFF control

Integral time = 1 to 6000s, or OFF (manual reset)

Derivative time = 1 to 6000s, or OFF

Manual reset value = -5.0 to 105.0% of output range  
(functions when integral time is off.)

ON/OFF control hysteresis = 0.0 to 100.0% of PV input range span (0.1 to 0.5% for heating/cooling control)

Setpoint rate-of-change setting = OFF, or 0.0 to 100.0%/h or min of PV input range span.

A PV tracking function operates automatically when the setpoint is changed, the power is turned on, or the mode is changed from manual to automatic.

**Direct/reverse action:**

The output increase/decrease direction can be defined corresponding to a positive or negative deviation.

For heating/cooling control, it is fixed to reverse for the heating-side output, and direct for the cooling-side output.

**Anti-reset windup:**

When controller output is limited, normal integration is superseded by an anti-reset windup computation to suppress over-integration.

Control output cycle time = 1 to 1000s (for time-proportional PID control) and (the cooling side output cycle time is also the same when heating/cooling control is used).

Preset output value = -5.0 to 105.0% of output range

**Output tracking:**

Whether the output bump is provided or not can be selected by changing the PID control mode.

**Output limiter**

Upper limit = Lower limit to 105.0% of output range

Lower limit = -5.0% of output range to upper limit

Heating/cooling dead band = -100.0 to 50.0% for output range

**● Signal Computation Functions****PV input computation:**

Bias addition (-100.0 to 100.0% of PV input range span), and first-order lag filter (time constant OFF or 1 to 120s)

**Contact input function:**

Target setpoint selection, Auto/Man operating mode switching, key lock parameter show/hide switching

Target setpoint selection can be done for either a 2-setpoint or 4-setpoint selection.

- If the 2-setpoint selection is set, Auto/Man mode switching can be used as well.

- If the 4-setpoint selection is set, Auto/Man switching and key lock parameter show/hide switching cannot be used together.

If key lock parameter show/hide switching is used, target setpoint selection and Auto/Man mode switching cannot be used.

**● Alarm Functions**

Seventeen types of alarm functions are provided. The alarm status is indicated by the alarm lamp on the front panel.

Also, three points among them can be output as relay contact outputs.

**Alarm types:**

PV high limit, PV low limit, Deviation high limit, Deviation low limit, De-energized on deviation high limit, De-energized on deviation low limit, Deviation high and low limits, High and low limits within deviation, De-energized on PV high limit, De-energized on PV low limit, SP high limit, SP low limit, Output high limit, Output low limit, Deviation high limit for target setpoint, Deviation low limit for target setpoint, De-energized on deviation high limit alarm for target setpoint, De-energized on deviation low limit alarm for target setpoint, Deviation high and low limits for target setpoint, Deviation within high and low limits for target setpoint, Sensor grounding alarm, Fault diagnosis output, and FAIL output.

**Alarm output:**

3 points. Any three points can be output as contact outputs among the above alarms. For heating/cooling control, if cooling side output is output as a relay contact, up to two alarm outputs can be used.

**Setting ranges for PV, deviation, setpoint and output alarms:**

PV/setpoint alarm:

-100.0 to 100.0% of PV input range

Deviation alarm:

-100.0 to 100.0% of PV input range span

Output alarm:

-5.0 to 105.0% of output range

Alarm hysteresis width:

0.0 to 100.0% of PV input range span

**Delay timer:**

0.00 to 99.59 (minute, second)

An alarm is output when the delay timer expires after the alarm setpoint is reached.

Setting for each alarm is possible.

**Stand-by action:**

Stand-by action can be set to make PV/deviation alarm OFF during start-up or after SP change until SP reaches the normal region.

**Sensor grounding alarm:**  
 An alarm is output after detecting a change in control output. If the moving average \* of control output is out of the setting range (between the high and low limits of the on/off rate) in spite of the deviation being within a fixed range (on/off rate detection span) and control being in stable condition, the sensor is judged to be in a grounding condition.  
 \* Moving average refers to the average value for output values sampled (five times) in every cycle time.  
**High- and low-limit setting range of on/off rate:**  
 -5.0 to 105.0% of output range  
**Detection band of on/off rate:**  
 0.0 to 100.0% of PV input range span.

**Fault diagnostic alarm:**  
 Input burnout, A/D conversion error, thermocouple reference junction compensation error

**FAIL output:**  
 Abnormality in software or hardware  
 When in fail, control output, retransmission output and alarm output become 0% output or OFF.

● **Display and Operation Functions**

**PV display:** 4-digit digital display for engineering data  
**Setpoint display:**

Various data, such as the setpoint (SP), are displayed by selection on the 4-digit digital display.

**Status indicating lamps:**

- 3 alarm indicator lamps: AL1, AL2, AL3
- 3 setpoint number indicator lamps: SP2, SP3, SP4 (Go off when SP1 is selected.)
- MAN operation mode lamp: MAN (lit in MAN mode)

**PV display color changing function “Active Color PV Display” :**  
 (Factory-set default : Fixed in red mode)  
 This function automatically changes PV display color by the action described below. Green-to-red or red-to-green changing action is selectable.

**Link to alarm 1 mode :**  
 Alarm OFF : green, Alarm ON : red  
 Setting of Alarm OFF : red, Alarm ON : green is possible.

**Link to alarm 1 and 2 mode :**  
 Alarm OFF : green, Alarm ON : red  
 Setting of Alarm OFF : red, Alarm ON : green is possible.

**SP deviation mode :**  
 Within the preset SP deviation : green,  
 Out of the preset SP deviation : red  
 Setting of within the preset SP deviation : red,  
 Out of the preset SP deviation : green is possible.  
 Deviation band is changeable using a parameter. The setting of either high limit deviation or low limit deviation is also possible.

**PV limit mode :**  
 Within the preset PV range : green,  
 Out of the preset PV range : red  
 Setting of within the preset PV range : red,  
 Out of the preset PV range : green is possible.  
 The range (high limit and low limit) is changeable using a parameter.

**Fixed color mode :**  
 PV display color is fixed in green or red.

**Operation keys:**  
 △ and ▽ keys:  
 Increases or decreases setpoints and various parameters.

**SET/ENT key:**  
 For data setting or call-up/selection of various parameters

**A/M key:** Switching of operation mode (Auto/Man)  
**SELECT display:**

A panel where operating parameters that are frequently changed during operation can be selected and registered. For example, by registering the alarm-1 setpoint in the SELECT display, the setpoint can easily be displayed during operation.

**Security function:**  
 An operation-inhibiting mode using a password is provided.

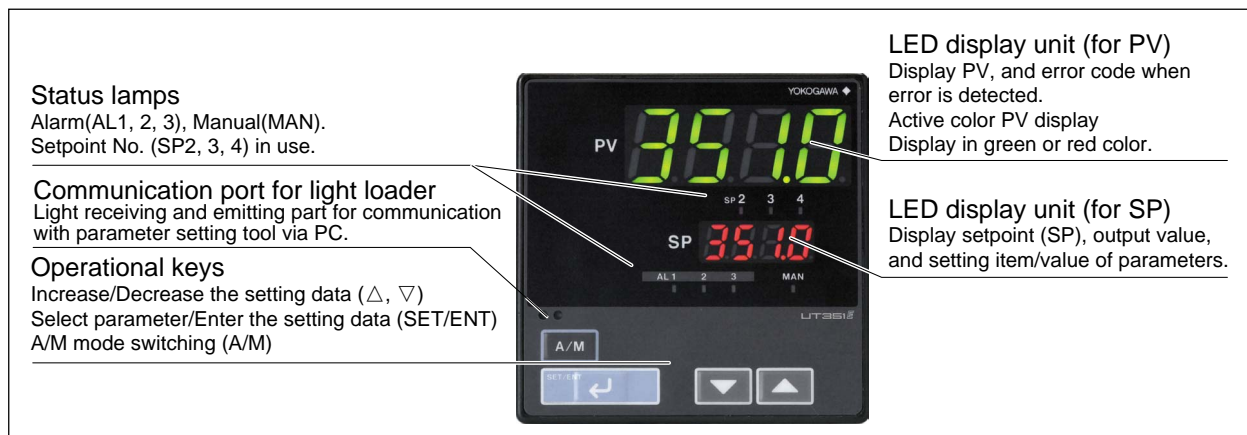

● **Communication Functions**

The UT351 has the embedded Ethernet to connect IEEE802.3-compliant network (10BASE-T/100BASE-TX). As a protocol, MODBUS/TCP communication function is supported, and communicate through port 502.

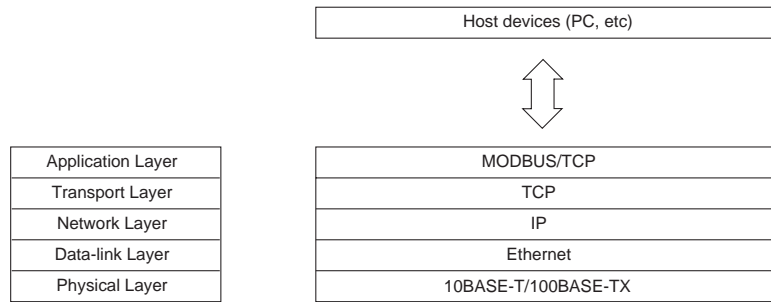

● **Communication Specifications**

Item	10BASE-T/100BASE-TX
Access Control	CSMA/CD
Transfer Rate	10Mbps/100Mbps
Max. Segment Length	100m <sup>Note1</sup>
Max. Connecting Configuration	Cascade Max. 4 level (10BASE-T), Max. 2 level (100BASE-TX) <sup>Note2</sup>

Note1: The length between Hub and Module.  
 Note2: The number of cascade connections per Hub.

● **Setting of IP Address**

IP Address used in Ethernet communication is set by keys on the front panel of the UT351, as a Setup parameter. Additionally, it is also settable by Light Loader, model LL100 PC-based Parameters Setting Tool (Order separately).

● **MODBUS/TCP Functions**

Applicable Function Codes and accessible data area of the UT351 by MODBUS/TCP are shown in the following tables.

Function Code	Function	Description
03	Reads data from multiple registers	Capable of reading data from up to 64 successive registers.
06	Writes data into register	Capable of writing to only one register.
08	Performs a loop back test	Capable to check communication connection
16	Writes data into multiple D-registers	Capable of writing to up to 32 successive registers.

D-Register No.	Area data categories		Description
D0001 to D0049	Process data area	Data displayed for operation	PV,SP,OUT, and others
D0050 to D0100	User area	_____	_____
D0201 to D0230	Operating parameters	Operation mode parameters	A/M, MOUT, and others
D0231 to D0300		Computation parameters	AT,SC,BS,FL,and others
D0301 to D0500		PID parameters	P,I,D and others
D0901 to D1000	Setup parameters	Control action parameters	TMU,ALM,C.MD
D1001 to D1100		Common function, Ethernet communication parameters	RET,IP1 and others
D1101 to D1200		SELECT display registration parameters	C.S
D1201 to D1300		PV input and control output, parameters	IN,OT

● Ethernet - Serial Gateway Functions

The UT351 has RS485 communication terminals in addition to Ethernet communication connector. The MODBUS/TCP command received via Ethernet is relayed to the RS485 communication terminals. This enables the connection to the devices with RS485 serial communication functions (MODBUS/RTU protocol) via network.

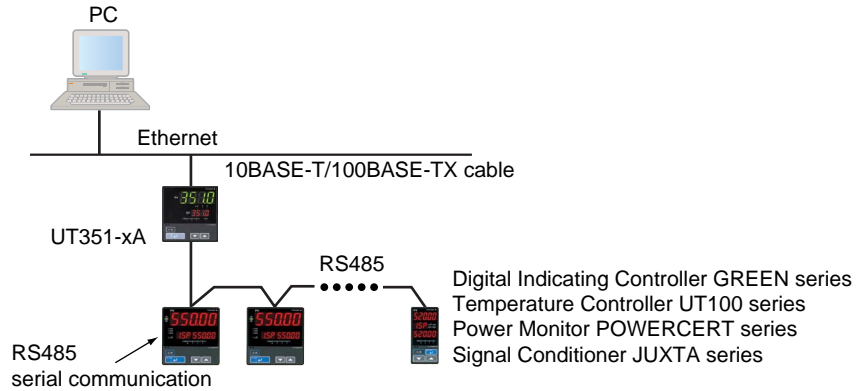

● Outline of MODBUS/TCP Protocol

The MODBUS/TCP frame structure is as follows.

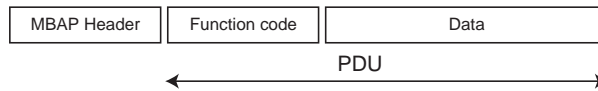

PDU (Simple Protocol Data Unit) and MODBUS/RTU (MODBUS protocol via serial communication) are the same.

MBAP Header (MODBUS Application Protocol Header) consists of the following 7 bytes.

Byte No	0	1	2	3	4	5	6
Description	Transaction ID		Protocol ID		Byte numbers		Unit ID

Transaction ID: The host device specifies an arbitrary value to identify a transaction. The UT351-xA returns the value it received from the host device as its response.

Protocol ID: This parameter is set to "0" to indicate the MODBUS/TCP protocol.

Number of bytes: The number of bytes from the Unit ID (byte number 6) byte on.

Unit ID: For the communication to the UT351 itself, specify "1" for the host device. The UT351 returns "1" as its response.

For the communication to the device connected to the RS485 communication terminals of the UT351 using Ethernet - serial gateway function, specify its communication address (2 to 99). The device returns the same value as its response.

● Configuration example of the communication system

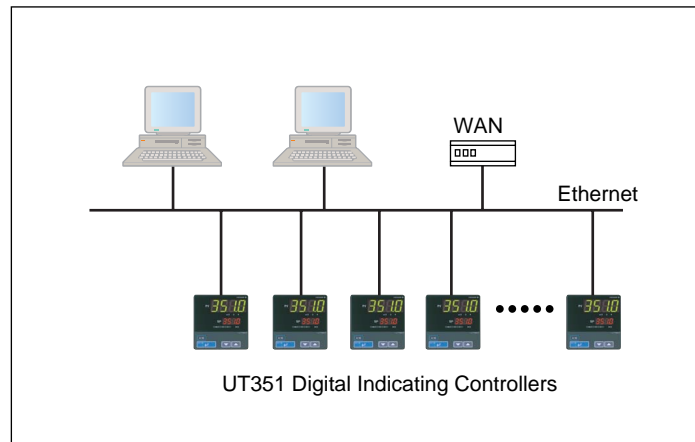

## ■ Hardware Specifications

### PV Input Signal

Number of input points: 1

Input system:

The type of input and instrument range can be specified using the table of PV input shown below by key operation or communication.

Input type, instrument range and measurement accuracy: Refer to the table below.

Input Type		Input range code	Instrument range (°C)	Instrument range (°F)	Measurement accuracy*1	
Unspecified(when shipped from the factory)		OFF	Set the data item PV input Type "IN" to the OFF option to leave the PV input type undefined.			
Thermocouple	K	1	-200 to 1370°C	-300 to 2500°F	±0.1% of instrument range ±1 digit for temperatures equal to or higher than 0 °C, ±0.2% of instrument range ±1 digit for temperatures below 0 °C	
		2	-199.9 to 999.9°C	0 to 2300°F		
		3	-199.9 to 500.0°C	-199.9 to 999.9°F		
	J	4	-199.9 to 999.9°C	-300 to 2300°F		
		5	-199.9 to 400.0°C	-300 to 750°F		
	T	6	0.0 to 400.0°C	-199.9 to 750.0°F		
		B	7	0 to 1800°C	32 to 3300°F	±0.15% of instrument range ±1 digit for temperatures equal to or higher than 400 °C ±5% of instrument range ±1 digit for temperatures below 400 °C
	S		8	0 to 1700°C	32 to 3100°F	±0.15% of instrument range ±1 digit
	R	9	0 to 1700°C	32 to 3100°F		
	N	10	-200 to 1300°C	-300 to 2400°F	±0.1% of instrument range ±1 digit ±0.25% of instrument range ±1 digit for temperature below 0 °C	
	E	11	-199.9 to 999.9°C	-300 to 1800°F	±0.1% of instrument range ±1 digit for temperatures equal to or higher than 0 °C	
	L (DIN)	12	-199.9 to 900.0°C	-300 to 1300°F	±0.2% of instrument range ±1 digit for temperatures below 0 °C	
	U (DIN)	13	-199.9 to 400.0°C	-300 to 750°F		
			14	0.0 to 400.0°C	-199.9 to 750.0°F	
	W	15	0 to 2300°C	32 to 4200°F	±0.2% of instrument range ±1 digit	
	Platinel 2	16	0 to 1390°C	32 to 2500°F	±0.1% of instrument range ±1 digit	
	PR20-40	17	0 to 1900°C	32 to 3400°F	±0.5% of instrument range ±1 digit for temperatures equal to or higher than 800 °C No guarantee of accuracy for temperatures below 800 °C	
	W97Re3-W75Re25	18	0 to 2000°C	32 to 3600°F	±0.2% of instrument range ±1 digit	
RTD	JPt100	30	-199.9 to 500.0°C	-199.9 to 999.9°F	±0.1% of instrument range ±1 digit (Note 1) (Note 2)	
		31	-150.0 to 150.0°C	-199.9 to 300.0°F	±0.2% of instrument range ±1 digit (Note 1)	
	Pt100	35	-199.9 to 850.0°C	-300 to 1560°F	±0.1% of instrument range ±1 digit (Note 1) (Note 2)	
		36	-199.9 to 500.0°C	-199.9 to 999.9°F		
		37	-150.0 to 150.0°C	-199.9 to 300.0°F	±0.2% of instrument range ±1 digit (Note 1)	
Standard signal	0.4 to 2V	40	0.400 to 2.000V	Scaling is enable in the following 4 range.	±0.1% of instrument range ±1 digit The read-out range can be scaled between -1999 and 9999.	
	1 to 5V	41	1.000 to 5.000V			
DC voltage	0 to 2V	50	0.000 to 2.000V	-1999 to 9999		
	0 to 10V	51	0.00 to 10.00V	-199.9 to 999.9		
	-10 to 20mV	55	-10.00 to 20.00mV	-19.99 to 99.99		
	0 to 100mV	56	0.0 to 100.0mV	-1.999 to 9.999		

Note 1: The accuracy is ±0.3°C of instrument range ±1 digit for a temperature range from 0 to 100°C.

Note 2: The accuracy is ±0.5°C of instrument range ±1 digit for an temperature range from -100 to 0°C and 100 to 200°C.

\*1: Performance in the standard operating condition (at 23°C ±2°C, 55±10%RH, and 50/60Hz power frequency)

\*2: To receive a 4 to 20mA DC signal, select a standard signal of 1 to 5V DC and connect it to a 250 ohm resistor. This resistor is optional.

Model : X010-250-2 (resistor with M3.5 crimp-on terminal lugs)

Sampling period: 250 ms

Burnout detection:

Functions with a thermocouple (TC), RTD, standard signal 0.4 to 2 V DC, and 1 to 5 V DC. Can be specified as upscale, downscale, and off. For standard signal, judged as burnout at 0.1 V or less.

Input bias current: 0.05 µA (for TC/RTD b-terminal)

Measuring current(RTD): About 0.13mA

Input resistance:

1 MΩ or more for TC/mV input  
About 1 MΩ for DC voltage input

Allowable signal source resistance:

250 Ω or less for TC/mV input; effect of permissible signal source resistance 0.1 µV/Ω or less 2 k Ω or less for DC voltage input; effect of permissible signal source resistance 0.01%/100 Ω or less

Allowable leadwire resistance:

Max. 150 Ω/wire (resistance in each of three wires must be equal) for RTD input However, max. 10 Ω/wire for a range of -150.0 to 150.0°C. Effect of permissible leadwire resistance ± 0.1°C/10 Ω or less

Allowable input voltage:

± 10 V DC for TC/mV/RTD input  
± 20 V DC for DC voltage input

Noise rejection ratio:  
 Normal mode 40 dB (50/60 Hz) or more  
 Common mode 120 dB (50/60 Hz) or more

Reference-junction compensation error:  
 $\pm 1.0^{\circ}\text{C}$  (15 to  $35^{\circ}\text{C}$ ),  
 $\pm 1.5^{\circ}\text{C}$  (0 to  $15^{\circ}\text{C}$ , 35 to  $40^{\circ}\text{C}$ )

Applicable standards: JIS, IEC, or DIN(ITS-90) for TC and RTD

Response time: 2 second or less, 63% (10 - 90%)  
 (The time required for transmission output to reach 63% of the maximum excursion when PV abruptly changes from 10% to 90%)

### Retransmission Output

Either PV, target setpoint, or control output is output. Either the retransmission output or the 15V DC loop power supply can be used.

Number of output points: 1  
 Output signal: 4 to 20 mA DC  
 Load resistance: 600  $\Omega$  or less  
 Output accuracy:  $\pm 0.3\%$  of span  
 \* Performance in the standard operating conditions (at  $23 \pm 2^{\circ}\text{C}$ ,  $55 \pm 10\%$  RH, and 50/60 Hz power frequency)

15V DC loop power supply:

Supply voltage is 14.5 to 18.0 V DC. Maximum supply current is about 21 mA (with a protection circuit for a field short-circuit).

### Control Outputs

The control output is of a universal scheme and can be selected from the following types of outputs. In the case of heating/cooling control, it is also selectable from these outputs. However, if the cooling side output is a relay contact output, the alarm-3 cannot be used, and similarly if the cooling side output is a voltage pulse or current output, the retransmission output/15 V DC sensor power supply cannot be used.

#### Current output

Number of output points: 1 or 2 (2 for heating/cooling type), switched between voltage pulse output and current output.  
 Output signal: 4 to 20 mA  
 Load resistance: 600  $\Omega$  or less  
 Output accuracy:  $\pm 0.3\%$  of span  
 \* Performance in the standard operating conditions (at  $23 \pm 2^{\circ}\text{C}$ ,  $55 \pm 10\%$  RH, and 50/60 Hz power frequency)

#### Voltage pulse output

Number of output points: 1 or 2 (2 for heating/cooling type), switched between voltage pulse output and current output.

Output signal:  
 On voltage = 12 V DC or more (load resistance of 600  $\Omega$  or more; current on short-circuiting about 30 mA)  
 Off voltage = 0.1 V DC or less

Resolution: 10 ms

#### Relay contact output

Number of output points: 1 or 2 (2 for heating/cooling type)  
 Output signal: Three terminals for NC, NO, and Common transfer-contact  
 Contact rating: 250 V AC, 3 A or 30 V DC, 3A (resistive load)  
 Resolution: 10 ms

### Contact Inputs

Usage: Target setpoint selection, Auto/Man mode switching, Run/Stop switching or Key lock parameter show/hide switching  
 Number of input points: 2  
 Input type: Non-voltage contact input or transistor open collector input

Input contact rating: 12 V DC, 10 mA or more (for non-voltage contact input)  
 On/off determination: For non-voltage contact input,  
 ON = contact resistance of 1 k $\Omega$  or less,  
 OFF = contact resistance of 20 k $\Omega$  or more.  
 For transistor contact input,  
 ON = 2 V or less,  
 OFF = leakage current of 100  $\mu\text{A}$  or less.  
 Minimum retention time for status detection: About 1 second

### Contact Outputs

Usage: Alarm output, FAIL output, and others  
 Number of relay contact output points: 3  
 Relay contact rating: 240 V AC, 1 A or 30 V DC, 1 A, normally open  
 (COM terminal is common for every contact output.)  
 (Normally close for FAIL output)

### ● Display Specifications

PV display: 4-digit, 7-segment green or red LED; character height - 20 mm  
 Setpoint display: 4-digit, 7-segment red LED; character height - 9.3 mm  
 Status indicating lamps: LEDs

### ● Conformance to Safety Standards

Safety: Complies with IEC/EN61010-1 (CE), approved by C22.2 No.61010-1, approved by UL508.  
 Installation category : CAT. II Pollution degree: 2 (IEC/EN61010-1, C22.2 No.61010-1)  
 Measurement category : I (CAT. I : IEC/EN61010-1)  
 Rated measurement input voltage : 10V DC max.(across terminals), 300V AC max.(across ground)  
 Rated transient overvoltage : 1500V (Note)  
 Note : It is a value on the safety standard which is assumed by IEC/EN61010-1 in Measurement category I, and is not the value which guarantees an apparatus performance.  
 EMC standards: Complies with EN61326, EN61000-3-2, EN61000-3-3 and EN55011 (CE).  
 AS/NZS 2064 compliant (C-Tick).  
 Class A Group 1.  
 During test, the controller continues to operate with the measurement accuracy within  $\pm 20\%$  of the range.

### ● Construction, Mounting, and Wiring

Construction: Dust-proof and Drip-proof front panel conforming to IP55.  
 For side-by-side close installation, the controller loses its dust-proof and drip-proof protection.  
 Material: ABS resin and polycarbonate  
 Case color: Black  
 Weight: About 1 kg  
 External dimensions:  
 96 (width)  $\times$  96 (height)  $\times$  100 (depth) mm  
 Mounting :Direct panel mounting; mounting bracket, one each for upper and lower mounting  
 Panel cutout dimensions:  $92_{0}^{+0.8}$  (width)  $\times$   $92_{0}^{+0.8}$  (height) mm  
 Mounting attitude:  
 Up to 30 degrees above the horizontal. No downward tilting allowed.  
 Wiring: M3.5 (ISO 3.5 mm) screw terminals (signal wiring and power/ground wiring as well)

## ● Power Supply Specifications and Isolation

Power supply: Rated at 100 to 240 V AC ( $\pm 10\%$ ), 50/60 Hz  
 Power consumption: Max. 20 VA (Max. 8.0 W)  
 Internal fuse rating: 250 VAC, 1.6A time-lag fuse  
 Memory back-up: Non-volatile memory (Service life about 100,000 times of writings)

Withstanding voltage:  
 1500 V AC for 1 minute between primary and secondary terminals.  
 1500 V AC for 1 minute between primary and ground terminals.  
 1500 V AC for 1 minute between ground and secondary terminals.  
 500VAC for 1 minute between two secondary terminals.

(Primary terminals = Power and relay output terminals)  
 (Secondary terminals = Analog I/O signal terminals, voltage pulse output terminals, contact input terminals)

Isolation resistance:  
 20 M $\Omega$  or more when 500 V DC voltage is applied between the power terminals and ground terminal.

Grounding:  
 Class D grounding (Class 3 grounding) (grounding resistance of 100  $\Omega$  or less)

## ● Isolation specifications:

PV input terminal:  
 Isolated from other I/O terminals. Not isolated from internal circuits.

15 V DC loop power supply terminals:  
 Not isolated from analog current output and voltage pulse control output. Isolated from other I/O terminals and internal circuit.

Control output (current or voltage pulse) and retransmission terminals: Not isolated between control output terminals and retransmission output terminals. Isolated from other I/O terminals and internal circuits.

Relay contact control output terminals:  
 Isolated from other I/O terminals and internal circuits.

Contact input terminals:  
 Not isolated from other contact input terminals mutually, and communication terminals. Isolated from other I/O terminals and internal circuits.

Relay contact alarm output terminals:  
 Isolated from other I/O terminals and internal circuits.

Ethernet communication terminal:  
 Isolated from internal circuits.

RS485 communication terminals:  
 Not isolated from contact inputs. Isolated from other I/O terminals and internal circuits.

Power supply terminals:  
 Isolated from other I/O terminals, ground terminal, and internal circuits.

Ground terminal:  
 Isolated from other I/O terminals, power terminals, and internal circuits.

## ● Environmental Conditions

Normal operating conditions:  
 Ambient temperature: 0 to 50°C (40°C or less for side-by-side close mounting)  
 Ambient temperature change limit: 10°C/h or less  
 Ambient humidity: 20 to 90% RH (no condensation)  
 Magnetic field: 400 A/m or less  
 Continuous vibration (5 to 14 Hz):  
 Peak-to-peak amplitude of 1.2 mm or less  
 Continuous vibration (14 to 150 Hz):  
 4.9 m/s<sup>2</sup> or less  
 Short-period vibration: 14.7 m/s<sup>2</sup>, 15s or less  
 Shock: 147 m/s<sup>2</sup> or less, 11 ms  
 Installation altitude: 2,000 m or less above sea level  
 Warm-up time 30 minutes or more after power on

Transportation and storage conditions:  
 Temperature: -25 to 70°C  
 Temperature change limit: 20°C/h or less  
 Humidity: 5 to 95% RH (no condensation)

Effects of operating conditions  
 Effect of ambient temperature:  
 For voltage or TC inputs:  
 Whichever is greater,  $\pm 1\mu\text{V}/^\circ\text{C}$  or  $\pm 0.01\%$  of F.S./ $^\circ\text{C}$   
 For RTD inputs:  
 $\pm 0.05^\circ\text{C}/^\circ\text{C}$  (ambient temperature) or less  
 For analog output:  $\pm 0.05\%$  of F.S./ $^\circ\text{C}$  or less  
 Effect of power supply fluctuation (within rated voltage range):  
 For analog input:  
 Equal to or less than whichever is greater,  $\pm 1\mu\text{V}/10\text{ V}$  or  $\pm 0.01\%$  of F.S./10 V  
 For analog output:  $\pm 0.05\%$  of F.S./10 V or less



**Function Block Diagram for Standard Type**

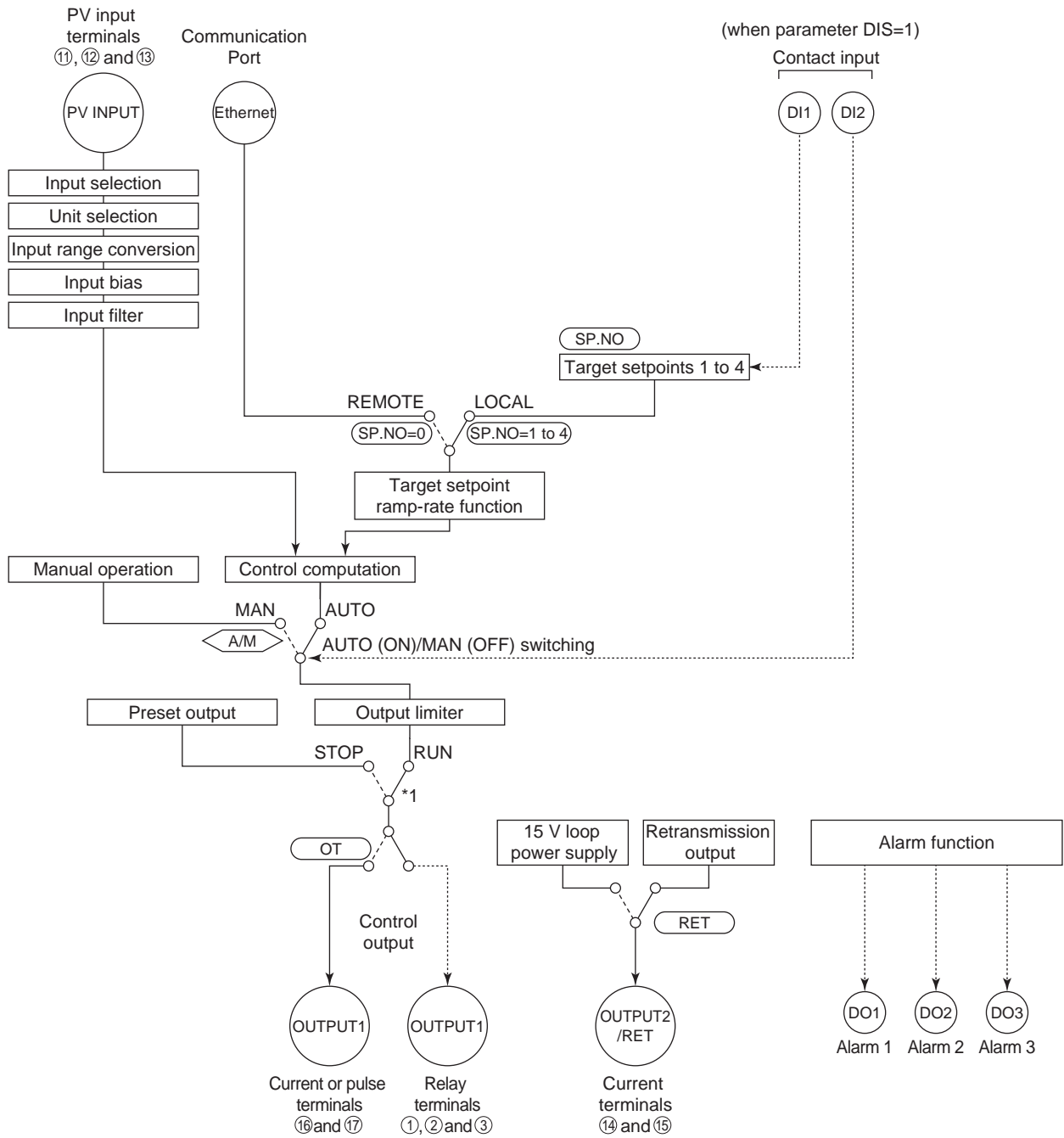

\*1: If the setup parameter DIS (DI function selection) is set to "4", when the contact input 2 is ON (run state), that controller outputs the preset output value.

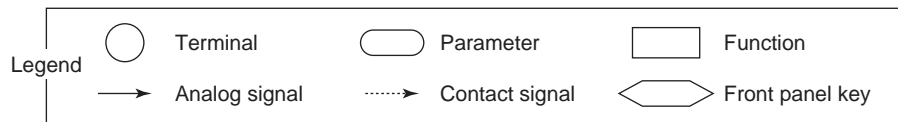

■ Function Block Diagram for Heating/Cooling Type

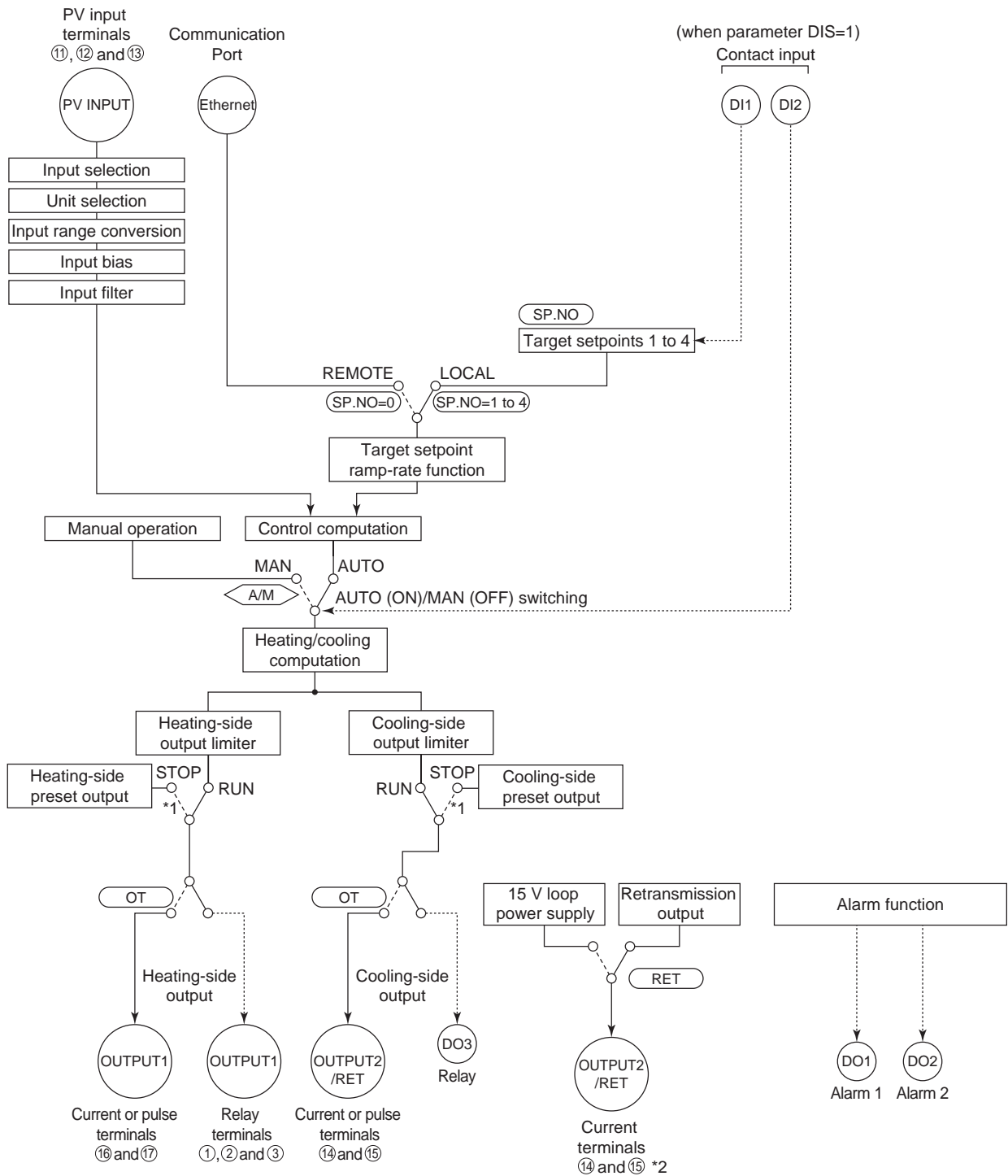

\*1: If the setup parameter DIS (DI function selection) is set to 4 ,  
when the contact input 2 is ON (run state), that controller outputs the preset output value.  
\*2: Unavailable when cooling-side control output is current or pulse.

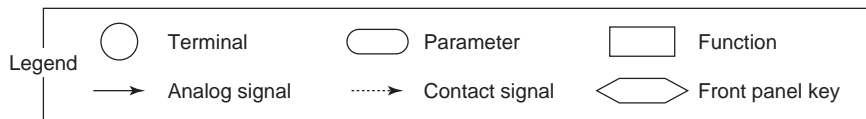

# Standard Type, Terminal Arrangements

**Control output**

Note: Select this option from the OT parameter.  
\* Time proportional PID relay contact output is configured at factory before shipment.

Relay contact output: 250 V AC, 3 A  
30 V DC, 3 A (resistance load)

Alarm output

Alarm-1 output AL1 6  
Alarm-2 output AL2 5  
Alarm-3 output AL3 4  
Common COM 7

Relay contact rating: 240 V AC, 1 A  
30 V DC, 1 A (resistance load)

**Power supply**

Power supply terminals: L 8, N 9, 10

Allowable range: 100 to 240 V AC (±10%)  
(free voltage)  
50/60 Hz shared

**Ethernet**

RJ-45 Connector

10BASE-T/  
100BASE-TX

Activity LED (upper side)

Color	Meaning
Off	No Activity
Amber	Half-duplex
Green	Full-duplex

Link LED (lower side)

Color	Meaning
Off	No Link
Amber	10 Mbps
Green	100 Mbps

RS-485 communication

23 SDB(+) →  
24 SDA(-) →  
25 RDB(+) →  
26 RDA(-) →

**For Gateway Function**

TC input

RTD input

m/VV input

Receiving 4-20 mA DC Current Signals with the Controller

\* When receiving 4-20 mA DC current signals, set the PV input type to 1-5 V DC (setpoint: 41).

Note: Connecting a 250 Ω resistor to the terminals is optional.  
Model: X010-250-2 (resistor with M3.5 crimp-on terminals)

**PV input** \* Not configured at factory before shipment

TC input

RTD input

m/VV input

Receiving 4-20 mA DC Current Signals with the Controller

\* When receiving 4-20 mA DC current signals, set the PV input type to 1-5 V DC (setpoint: 41).

Note: Connecting a 250 Ω resistor to the terminals is optional.  
Model: X010-250-2 (resistor with M3.5 crimp-on terminals)

**Control output**

Current/voltage pulse output

16 + 4-20 mA DC, voltage pulse (1.2 V)  
17 -

Note: Select this option from the OT parameter.

**Retransmission output**

14 + 4-20 mA DC  
15 -

15 V DC, loop power supply

14 + 14.5-18.0 VDC (21 mA DC max.)  
15 -

\* PV retransmission is configured at factory before shipment.

Load resistance: 600 Ω or less

\* If 15 V DC loop power supply is used, retransmission output cannot be used.

**Contact Input**

Transistor contact

+5V DI1 19  
+5V DI2 18  
COM 20

Contact rating: 12 V DC, 10 mA or more

\* DIS is a setup parameter.  
Changing DIS setpoint allows you to change the function of external contact input.

Correspondence between parameter DIS and external contact input functions	
When DIS=OFF	When DIS=1 (Factory-shipped setting) 2.SP when DI1=ON 1.SP when DI1=OFF
No function	Hides the LOCK parameter when DI1=ON. Shows the LOCK parameter when DI1=OFF.
No function	AUTO when DI2=ON MAN when DI2=OFF
Common	Common
When DIS=2	When switching target SP-1 to 4: DI1 OFF ON OFF ON DI2 OFF OFF ON ON
No function	No function
Common	Common
When DIS=3	When DIS=3 2.SP when DI1=ON 1.SP when DI1=OFF
Common	Common
When DIS=4	When DIS=4 2.SP when DI1=ON 1.SP when DI1=OFF
Common	Common

\* OT is a setup parameter. You can change the settings of the parameter OT to change the control output type.

Correspondence between parameter OT and control output types

OT=0 (factory-shipped setting)	OT=1	OT=2	OT=3
Time proportional control	Time proportional control	Current output	On-off control
Relay output (terminals ①, ② and ③)	Voltage pulse output (terminals ① and ②)	Relay output (terminals ①, ② and ③)	Relay output (terminals ①, ② and ③)

# Heating/Cooling Type, Terminal Arrangements

**Heating-side control output**

Relay contact output

\* Time proportional PID relay contact output is configured at factory before shipment.

\* Available if 4, 7 or 10 is set in the OT (Control Output Type) setup parameter.

Contact rating: 250 V AC, 3 A  
30 V DC, 3 A (resistance load)

**Alarm output/cooling-side control output**

Alarm-1 output  
Alarm-2 output  
Alarm-3 output or cooling-side control output (Note)  
Common

Relay contact rating: 240 V AC, 1 A  
30 V DC, 1 A (resistance load)

Note: The cooling-side control output is selected if 4, 5 or 6 is set in the OT (Control Output Type) setup parameter. The alarm-3 output is not available. The controller is factory-set to the cooling-side control output (time proportional PID relay contact output).

**Power supply**

Before carrying out wiring, turn off the power to the controller and wait for the capacitors are not fully with a tester or the like because there is a possibility of electric shock.

Allowable range: 100 to 240 V AC (±10%)  
(free voltage)  
50/60 Hz shared

**Ethernet**

RJ-45 Connector

10BASE-T/100BASE-TX

**For Gateway Function**

RS-485 communication

SDA(+)  
SDA(-)  
RDB(+)  
RDB(-)

Activity LED (upper side)  
Color: Off (No Activity), Amber (Half-duplex), Green (Full-duplex)

Link LED (lower side)  
Color: Off (No Link), Amber (10 Mbps), Green (100 Mbps)

**PV input** \* Not configured at factory before shipment

TC input

RTD input

mV/V input

**Receiving 4-20 mA DC Current**

Signals with the Controller

\* When receiving 4-20 mA DC current signals, set the PV input type to 1-5 V DC (sepoint 41).

Note: Connecting a 250 Ω resistor to the terminals is optional.  
Model: X010-250-2 (resistor with M3.5 crimp-on terminal lugs)

**Retransmission output**

15 V DC loop power supply

14.5-18.0V DC (21 mA DC max.)

4-20 mA DC

14.5-18.0V DC (21 mA DC max.)

14.5-18.0V DC (21 mA DC max.)

14.5-18.0V DC (21 mA DC max.)

\* PV retransmission is configured at factory before shipment.

\* If 15 V DC loop power supply is used, retransmission output cannot be used.

\* The retransmission output and 15 V DC loop power supply are not available if the cooling-side control output is set to current output and voltage pulse output.

**Heating-side control output**

Current/voltage pulse output

\* Available if 5, 6, 8, 9, 11 or 12 is set in the OT (Control Output Type) setup parameter.

16.5 mA DC voltage pulse (12 V)

16.5 mA DC voltage pulse (12 V)

**DIS is a setup parameter.**

Changing DIS sepoint allows you to change the function of external contact input.

When DIS=1 (Factory-shipped setting)		When DIS=2		When DIS=3		When DIS=4	
No function	2.SP when DI1=ON 1.SP when DI1=OFF	No function	Hides the LOCK parameter when DI1=ON Shows the LOCK parameter when DI1=OFF.	When switching target SP 1 to 4	2.SP when DI1=ON 1.SP when DI1=OFF	When DIS=4	2.SP when DI1=ON 1.SP when DI1=OFF
No function	AUTO when DI2=ON MAN when DI2=OFF	No function		DI OFF/ON OFF/ON DI2 OFF/ON OFF/ON	STOP when DI2=ON RUN when DI2=OFF	COM	COM
Common	Common	Common	Common	Common	Common	Common	Common

Correspondence between parameter DIS and external contact input functions

**OT is a setup parameter.**

You can change the settings of the parameter OT to change the control output type.

OT=4 (factory-shipped setting)		OT=5		OT=6		OT=7		OT=8		OT=9		OT=10		OT=11		OT=12	
Heating side: Relay output (terminals ① and ③)	Heating side: Relay output (terminals ① and ③)	Heating side: Current output (terminals ② and ③)	Heating side: Voltage pulse output (terminals ④ and ⑤)	Heating side: Current output (terminals ② and ③)	Heating side: Voltage pulse output (terminals ④ and ⑤)	Heating side: Relay output (terminals ① and ③)	Heating side: Voltage pulse output (terminals ④ and ⑤)	Heating side: Current output (terminals ② and ③)	Heating side: Voltage pulse output (terminals ④ and ⑤)	Heating side: Current output (terminals ② and ③)	Heating side: Voltage pulse output (terminals ④ and ⑤)	Heating side: Relay output (terminals ① and ③)	Heating side: Voltage pulse output (terminals ④ and ⑤)	Heating side: Current output (terminals ② and ③)	Heating side: Voltage pulse output (terminals ④ and ⑤)	Heating side: Current output (terminals ② and ③)	Heating side: Voltage pulse output (terminals ④ and ⑤)
Cooling side: Relay output (terminals ④ and ⑤)	Cooling side: Relay output (terminals ④ and ⑤)	Cooling side: Current output (terminals ② and ③)	Cooling side: Voltage pulse output (terminals ④ and ⑤)	Cooling side: Current output (terminals ② and ③)	Cooling side: Voltage pulse output (terminals ④ and ⑤)	Cooling side: Relay output (terminals ④ and ⑤)	Cooling side: Voltage pulse output (terminals ④ and ⑤)	Cooling side: Current output (terminals ② and ③)	Cooling side: Voltage pulse output (terminals ④ and ⑤)	Cooling side: Current output (terminals ② and ③)	Cooling side: Voltage pulse output (terminals ④ and ⑤)	Cooling side: Relay output (terminals ④ and ⑤)	Cooling side: Voltage pulse output (terminals ④ and ⑤)	Cooling side: Current output (terminals ② and ③)	Cooling side: Voltage pulse output (terminals ④ and ⑤)	Cooling side: Current output (terminals ② and ③)	Cooling side: Voltage pulse output (terminals ④ and ⑤)

Correspondence between parameter OT and heating-side/cooling-side output types

**Note:** External Contact Input

If the power is turned on when the external contact input is OFF, the mode (SP NO or A/M) existing before the power is turned off will be continued (except for RUN/STOP)

Contact rating: 12 V DC, 10 mA or more

## External Dimensions and Panel Cutout Dimensions

Unit: mm

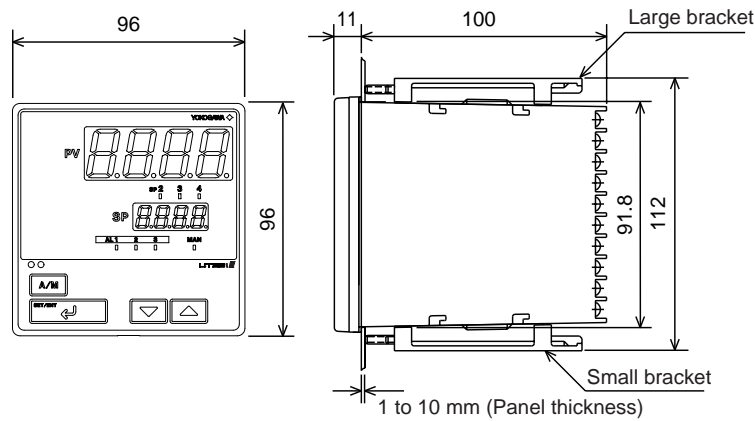

General installation

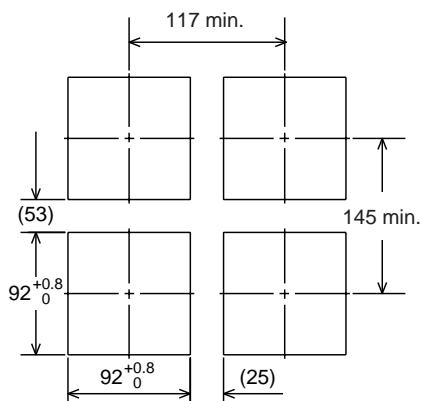

Side-by-side close installation

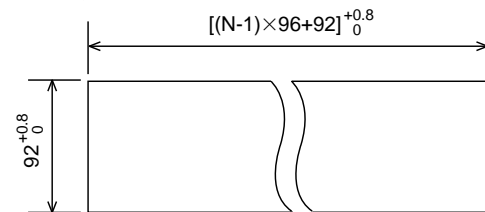

"N" stands for the number of controllers to be installed.  
However, the measured value applies if  $N \geq 5$ .

Normal Allowable Deviation =  $\pm$  (Value of JIS B 0401-1999 tolerance grade IT18) / 2

## Model and Suffix codes

Model	Suffix Code	Description
UT351		Digital indicating controller (provided with retransmission output and 15 V DC loop power supply as standard)
Type	-0 -2	Standard type Heating/cooling type
Optional functions	A	With Ethernet communication function

Standard Accessories: Brackets (mounting hardware), unit label, User's Manuals.

## Items to be Specified when Ordering

Model and suffix codes, necessary/unnecessary of User's Manual or QIC.